

**BUILDING CONSTRUCTION WORK REQUIRED FOR
THE ALTERATION, VERTICAL and HORIZONTAL
EXTENSION to the COLLEGE BUILDING
of
SARDAR PATEL INSTITUTE OF
TECHNOLOGY, BHAVAN'S CAMPUS,
ANDHERI WEST
MUMBAI**

**CONDITIONS OF THE CONTRACT
&
BILL OF QUANTITIES**

Tender form: Rs. 10,000/-

**[only in the form of DD in favor of Principal,
Sardar Patel Institute of Technology, to be
submitted along with the hard copy of the bid]**

Terms and Conditions

1. Workmanship should be good. Work of a substandard nature will not be accepted and paid for.
2. Contractor shall use only the best materials, preferably ISI marked, approved by the Institute appointed structural consultant for the project, during execution of the work.
3. All the released serviceable materials shall be handed over to the college at site and should be stacked neatly as directed by the Engineers and debris shall be carried out of the college premises as when directed by Engineers, which shall not be paid separately. Contractor shall quote his rates accordingly.
4. All reinstatement work shall be done by the contractor to match with the surrounding surfaces at his own cost and shall not be paid separately.
5. The contractor shall not be allowed to carry out any job on the college work site other than that required for the satisfactory completion of the college work.
6. The contractor should work in co-ordination and co-operation with the Agency already working on site and other agencies which may be engaged by the college during the progress of work.
7. The measurement will be taken jointly, and the contractor should submit the bills duplicate regularly.
8. The contractor will store the material at his cost and risk. Such storage should not disturb the normal working of the college.
9. The College authorities will test the materials at this college at contractor's cost.
10. The contractor is wholly responsible for the safety measures at site, and he shall insure his labor/supervisory staff against any mishap under workmen's compensation Act as well as Third party insurance scheme. The Contractor shall adopt all safety measures as per the requirement of the work.
11. Any defect in workmanship is to be rectified by the contractor at his own cost.
12. If any damage occurs to the college property during the execution of the work, the contractor shall make it good at his own cost.
13. Working conditions: The contractors will have to adopt staggered work timings so as not to create disturbance to the running of classes, laboratory practical's etc. Hence, discontinuity created during the work should be appropriately envisaged and rates quoted accordingly. The Contractor shall visit the site before quotation and if in doubt about any work item or specification then he shall contact our Consultant for clarifications.
14. The College Authorities competent to dispose of the tenders shall have the right of rejecting all or any of the tenders.
15. Quantities shown in the tender are approximate and payment shall be done as per the actual measurements taken after completion of the work.
16. No contractor shall employ any person who is under the age of 18 years.
17. The contractor shall not enter upon or commence any portion or work except with written permission from the authority. Failing such, the Contractor shall have no claim to ask for measurements of or payment for work.

18. Contractor shall see the Scope of work carefully and quote the rates accordingly.
19. Principal is final authority in case of dispute about quality of material, execution and other etc. His decision shall be binding on contractor and no claim shall be entertained.
20. Contractor must work as per schedule approved by Institute appointed structural Consultant & under the supervision of civil engineer appointed by college & SPIT civil engineer.
21. Contractor shall not sublet the work.
22. Rates are inclusive of all taxes. No claim shall be entertained for any extra taxes and contractor shall bear all the taxes.
- 23. Contractors shall plan their work activities such that common utilities like tower crane, double scaffolding shall be utilized to its maximum for other work items as well.**
- 24. 5% Security deposit will be deducted from the final bill for 12 months.**
25. Contractor will ensure the compliance of all relevant regulations, rules, norms, guidelines, provisions under relevant laws, related with respect to the construction, and alteration of the building. Institute will not be responsible for any issue regarding the non-fulfillment.
26. Contractor will use material of approved brand as per Consultant's recommendations only.
- 27. Contractor will submit EMD of Rs.10,00,000 /- along with the tender.**
28. Being college premises work, there may be movement of students, other persons. Contractor should take all measures of safety, for any accident contractor will be held responsible.
29. For any electrical use for this work from college network, contractor should contact to our college electrical appointed contractor Mr Nishant Shinde of M/s Ganesh Electricals (mob no-9820988760) for safety electrical work.
30. Please contact our consultant Mr. Godbole (abhaygodbole@hotmail.com)/ 8850818361 or institute supervisor Mr. Hemant (9869225326)

Seal & Signature of Contractor

DECLARATION OF THE CONTRACTOR

I/We hereby declare that I/we have made myself/ourselves thoroughly conversant with the local conditions regarding all materials and labour on which I/We have based my/our rates for this tender and also and conditions of contract. The specifications and lead, lift of this work have been carefully studied and understood by me before submitting this tender. I/We undertake to use only the best materials approved by the Engineers or his duly authorized assistant during execution of the work and to abide by his decisions. I/We hereby further declare that my/our tender is unconditional in every manner of whatsoever nature.

Seal & Signature of Contractor

Bill of Quantities for SPIT Extension Project

ELIGIBILITY

- Contractor should be registered contractor with Central /State Government Public undertaking / Municipal corporation / reputed private industries.
- The contractor should have executed similar work in past 3 years. The contractor should submit recommendations from the customers of repute and provide their contact information.
- The contractor should have paid Income tax, GST and other mandatory things for the financial year 22-23 and 23-24.

TENDER SCHEDULE

Tender document open	From: 17 th March. 25 to 27 st March. 25 upto 4 p.m.
Pre bid meeting	24 th March 25 at 11 am in Principal's office
Submission of the quote	From: 17 th March. 25 to 27 th March. 25 upto 5 p.m.
Bid opening evaluation	27 th March. 25 at 5:30 p.m.
Award of Contract	31 st March 2025
Commencement of the work	02 nd April 2025
Completion of the work	31 st Dec 2025

- 1. All bidders are advised to personally inspect the site before bidding for the contract.**
- 2. All sealed envelopes to be personally handed over to Ms. Aruna Nair (Principal Office on or before 27th March 25 up to 5 pm.**

Bill of Quantities for SPIT Extension Project

SI No	Description	Quantity	Unit	Rate	Amount
1	Breaking and carting away debris of old brick bat coba avg 150 thk using electric breaker without damaging lower RCC slab & exposing clean surface of RCC slab and carting away debris as instructed and as directed by the Engineer in charge	2000	m2		
2	Breaking and carting away debris of old RCC members/ water tank using electric breaker, cutting of reinforcement bars without damaging lower RCC slab as instructed and as directed by the Engineer in charge	100	m3		
3	Providing, supplying, erecting and fabricating ms structural steel sections of various sizes and length and of approved brands like Tata, Jindal etc. as per the design drawing with doble coat of zinc chromate& final painting with required scaffolding, use of tower crane etc complete. (Quote for labour only as Steel will be supplied by SPIT)	570	MT		
4	Providing, supplying, fixing in postion ms puff roof sheets 60mm thick metal roof sheets of				

approved make Like JSW or
equivalent with top sheet 0.8mm and
bottom sheet 0.5mm including all fixture
details and making it water proof etc as directed 1400 m2

- 5 Providing, supplying approved make light weight concrete blocks like siporex etc. of given thickness and constructing wall in CM 1:3 mortar including provision of band stiffeners etc complete as directed and as per the instruction of Engineer in charge
- | | |
|------------|---------|
| | 0 |
| a) 200 Thk | 1900 m2 |
| b) 100 Thk | 1475 |

- 6 Providing and laying marble mosaic/vitrified ceramic tiles for dado/flooring of approved quality 25 to 30 mm thick and having size around 60x60cm in plain /diamond pattern on bed of cement mortar 1:6 including cement floating, filling joints with neat cement slurry, curing, polishing and cleaning complete as directed 4300 m2

7

Providing and fixing 18mm thick black granite on window bottom for fixing aluminium windows track, marble to be in double layer with edge matching as per specimen and as directed 500 m

8

Providing and fixing aluminium sliding with powder coating 20mmx40mm aluminium section of specified track 18 guage thick windows of about

2.1mx2.1m or as per detailed drawing with powder coating including glazing with 5mm thick Modiguard glass panes of approved quality and make and bearings etc as per specimen and as directed and all fixtures and fastenings, scaffolding painting etc complete as directed and instructed.

	0 Nos
a) two Track	25 Sqm
b) three track	180 Sqm
c) Four Track	170 Sqm
d) Fixed glazing	25 Sqm
	Nos

9

Providing and fixing aluminium framed glass louvred adjustable window .6x.9m with hold fast etc all fixtures complete as instructed by site engineer

4 Nos

10

Providing fixing anodized Aluminium framed single/double leaf door with 12mm thick flat pressed teak wood particle board in panels as per detailed drawing or as directed including brass fixtures and fastening like hinges, towerbolts, aldrop, screws, handles etc and finishing the wood panel work with a coat of primer etc complete.

a Double panel door approx 1.2x2.1m	1 Nos
b single door .8x2.1m	38 Nos

11

Providing and fixing in position anodized extruded aluminium partitions, partly glazed and partly laminated having frame made out of extruded tubular section of size 40x60mm

- with 12mm thick three layered flat pressed teak wood particle board bonded with approved make resin conforming to IS 12823 laminated on both sides and 5mm thick glass panels of approved make with rubber cushioning beading etc of soundproof quality and complete as directed by Engineer in charge 0 QRO m2
- 12 Providing sand face plaster externally to siporex wall surface using approved screened sand including preparing base, watering applying base coat of 15mm thick in CM 1:4 using approved make super plasticizer 1% by weight of cement etc as directed curing the same for min 2 days keeping surface of the base coat rough to receive the sand face treatment not more than 8mm thickness in CM 1:4 and finishing the surface by taking out grains and curing for 14days with double scaffolding etc complete as directed. 2800 m2
- 13 Providing internal cement plaster 15mm thick single coat in CM 1:3 with gypsum finish to all surface etc complete as directed. 4800 m2
- 14 Providing & applying two coats of Asian Paints Apex Ultima to external walls of approved shade and as per manufacturers specification including one coat of Asian Paints Smartcare Primero and preparing the surface, washing the walls by using jet spray removing the dust, dirt including sturdy scaffolding as directed by the Site Engineer

- etc complete. The Contractor should provide warrantee certificate by the manufacturers. 3500 m2
- 15
Dismantling the existing steel structure/staircase including sections like joists, columns, ms plates at any height using gas cutting etc and carting away debris or stacking as directed and instructed by site engineer etc complete. 2 MT
- 16
Providing & applying plastic paint of approved make and colour to the internal plastered surface including scaffolding, surface preparation, watering etc complete as directed. 4800 m2
- 17
Providing and fixing white glazed earthenware urinal of approved make without flushing cistern with fittings, inlet pipe, stop tap, brackets for fixing the cistern, 32 mm dia galvanised iron heavy type flush pipe with fittings and flushing spreader arrangement etc. complete 8 Nos
- 18
Providing and fixing European type white glazed earthenware wall mounted water closet including P trap, cast iron soil and vent pipes with low level white glazed 10 litres cistern with black backelite seat and lid with chromium plated brass hinges including 100mm dia plug bend, inlet pipe, stop tap etc with all fittings, cutting and making good walls and floors complete 8 Nos
- 19

- Providing and Constructing granite counter 2' wide & 2'6" in height including use of approved granite of 1" thickness, making frame by using double vertical kadappa below granite, moulding dhar patti of granite on front edge and vertical joints and fixing 2nos of white glazed wash basins in platform cutting granite including polishing. All exposed surfaces should be mirror polished and two vertical sides of granite slab-2'3"x2'6" height including bottle traps etc. all fitting accessories etc complete 5 Nos
- 20
Providing waterproofing in WC and urinals and bath including brick bat coba overall 100mm thick in all position including providing and laying 12mm bedding cement mortar 1:3 with waterproofing compound @ 1kg/cement bag laying brick bat coba of required thickness in CM 1:5 with above waterproofing compound in 1kg/bag ratio for cement grouting and finishing the top layer with 20mm thick brick bedding in CM1:3 with waterproofing compound and testing the portion for 48 hrs by ponding and covering ten years guarantee including curing etc complete 25 m2
- 21
Providing and fixing G.I. pipes ISI marked to walls, ceiling, floors etc with screwed sockets, backnuts, elbows, tees reducers, enlargers, plugs, clamps etc including necessary grilling holes in walls slabs etc and remaking good the demolished portion to original condition applying primer and two coats of oil paint including necessary

scaffolding etc as directed etc complete.

- | | |
|---|-----|
| a) 15mm dia 21.3mm OD and 1.27kg/m weight | 5 m |
| b) 20mm dia 26.9mm OD and 1.64kg/m weight | 5 m |
| c) 25mm dia 33.7mm OD and 2.53kg/m weight | 5 m |
| d) 40mm dia 48.3mm OD and 3.73kg/m weight | 5 m |

22

Providing and fixing PVC Nahani trap with fixed stainless steel grating, PVC plug bend and piece of PVC pipe upto plug bend etc. complete 10 Nos

23

Providing and fixing 15 mm dia standard bib cock/ push cock/stopcock or pillar cock of approved make including socket, union, nuts etc. complete 33 Nos

24

Providing and fixing PVC soil/waste water pipes having wall thickness of 3.2 to 3.8 mm conforming to IS:13592-1992 including PVC plug bends, necessary fitting such as bend, tees, single junction, double junction, slotted vent offsets on walls/floors including fixing the pipe on wall using approved cleats projecting 25 to 40mm from the wall and fixing with clips of approved quality and nos, filling the joints using rubber gaskets with solvent cement including necessary scaffolding screwing cleaning the surface and applying primer two coats of paint as directed and instructed by the Site Engineer etc complete

- | | |
|--------------------|------|
| a) 75mm outer dia | 10 m |
| b) 110mm outer dia | 10 m |
| c) 50mm dia CPVC | |

25

Providing and fixing High density Polyethylene UV stabilized three layered sintex make water storage tank of various sizes including conveying and hoisting in position conforming to IS:12701 with all leads and lifts and making necessary connections, testing and all required accessories including steel ladder etc complete as directed and instructed by Site Engineer

10000 Litre

26

Providing and fixing PVC Rain water pipes having wall thickness of 2.2 to 2.7 mm conforming to IS:13592-1992 including proper rain water receiving recess with PVC plug bend, necessary fittings such as offsets, shoes including fixing of pipe on the wall using approved cleats projecting to 40mm away from face of wall and fixing with clips of approved quality and numbers, filling the joints using rubber gaskets with solvent cement and properly resting the shoe of pipes on walls , columns, beams etc. including necessary scaffolding etc. as directed and instructed by Site Engineer etc complete.

a) 110/160mm outer dia

380 m

27

Providing and fixing in wall on both sides of urinal prepolished granite divider of required size as per approved sample with all exposed edges shall be bull nosed moulding with mirror polish surface etc

- complete as directed and instructed. 8 Nos
- 28
 Providing and casting in situ dense and impervious cement concrete of M-30 grade with 20mm trap metal for Pile caps, RCC beams, Lintels or internal chajjas as per detail design and drawings or as directed including providing and erecting steel centering and shuttering with strutting, propping etc and removal of formwork, necessary compaction, curing finishing the formed surface with cement mortar 1:3 of sufficient minimum thickness to give smooth and even surface. Any defect distress if seen should be immediately repaired by the Contractor. 120 Cum
- 29
 Providing and fixing mild steel grill work for windows, ventilators weighing 15 kg/sqm as per drawing/sample including necessary welding and painting with one coat of zinc chromate and two coats of oil paint of approved colour shade of anticorrosive paint etc. complete as directed and instructed by Site Engineer. 500 Sqm
- 30
 Providing and fixing in position m.s./TOR/TMT bars of various diameter of Tata CRS Fe415 grade for Pile caps, beams, slabs, columns or chajjas lintels etc as per detailed design drawing and schedules including cutting bending hooking the bars, binding them with binding wires or tack welding and supporting as required or as directed, instructed complete. 11 MT

31

Providing and fixing in position precast siporex slabs of .75x2.44 m size & .1 m Thick at required position for windows Cill and lintel levels finishing with side siporex wall in 1:3 cement mortar as per drawing, or direction or as instructed etc. complete 100 Nos

32

Providing and fixing anchor fasteners of approved make like Hilti or equivalent as per drawing or as directed and instructed of 12mm dia 150 long complete 480 Nos

33

Supplying, fixing and installation of 4mm thick Aluminium Composite Panel of approved colour for external cladding in combination of solid and metallic colours, including all necessary framework, support and complete weather sealing as required by Site Engineer/drawing. The Aluminium Composite Panel should be made out of thermoplastic core of low density polyethylene sandwiched between two aluminium sheets as per normal standards. The supporting framework shall be made out of 50x25x3 mm thick aluminium section to be spaced horizontally and vertically for fixing panel of size 900x1200mm fixed to building structure as per design through 50x50x5 ms angle clamps welded to structural sections. The fixing of panels to be done with VHB tapes and screws and sealing of all the joints to be done with weather sealant Silicon as directed and instructed by

Engineer in charge.

QRO
125 m2

34

Providing and fixing UPVC pipes ISI marked to walls, ceiling, floors etc with screwed sockets, backnuts, elbows, tees reducers, enlargers, plugs, clamps etc including necessary grilling holes in walls slabs etc and remaking good the demolished portion to original condition applying primer and two coats of oil paint including necessary scaffolding etc as directed etc complete.

a) 50mm dia	11 Rm
b) 25mm dia	21 Rm
c) Ball cock	4 Nos
d) CPVC 50mm dia	30 Rm
e) UPVC 15mm dia	70 Rm

35 Providing & applying redimix polymer mortar 30mm thick of Sunanda Brand as per their specification complete in all respects

40 kg

36

Providing and applying polyalk EP coating of Sunanda Brand by mixing in specified proportion with cement as per their specifications complete in all respects and as directed.

1000 Sqm

37 Providing and applying membrane waterproofing of specified brand complete in all respects and as directed

110 Sqm

- 38 Providing and applying IPS as top most layer as per requirement and as directed complete in all respects. 100 Sqm
- 39 Providing and fixing chickenmesh in the plaster at the junction of steel and siporex wall junction for crackproof plaster complete in all respects and as directed. 800 Sqm
- 40 Same as Item 8 but for removal and refixing of old windows
- a) two Track 1 Sqm
 - b) three track 90 Sqm
 - c) Four Track 200 Sqm
 - d) Fixed glazing 1 Sqm
- 41 Providing and fixing in position circular column cladding of required thickness and 750mm diameter to stilt level columns of approx 7.62m height in flowing materials including two coats of external painting as required complete as directed. Internal steel framing to be paid separately under fabrication item.
- a) Fiberglass 8/10 thick 12 Nos
 - OR
 - b) Aluminium Composite Panels 12 Nos
- 42 Providing & fixing in position inside pile cap or other RCC members, ms inserts threaded bars of required size & shape as per the design & as directed complete 2 MT
- 43 Excavation in all types of soft/hard

murrum upto a depth of 1.5 to 2.0 m including clearing excavated soil from the site to indicated location inside the campus or outside.	130 m3
44 Barricading the site with minimum 15' high barricade as per design drawing and/or as per MCGM Requirements complete in all respects or as directed	125 Rm
45	
Providing and fixing double safety net 12' all around the structure with required framing in ms steel framing as per design or as directed including dismantling the same and raising it to the required level for ensuring safety etc. complete	
a) Middle wing	LS
b) Front middle wing	LS
c) West wing	LS

Total
With GST 18%

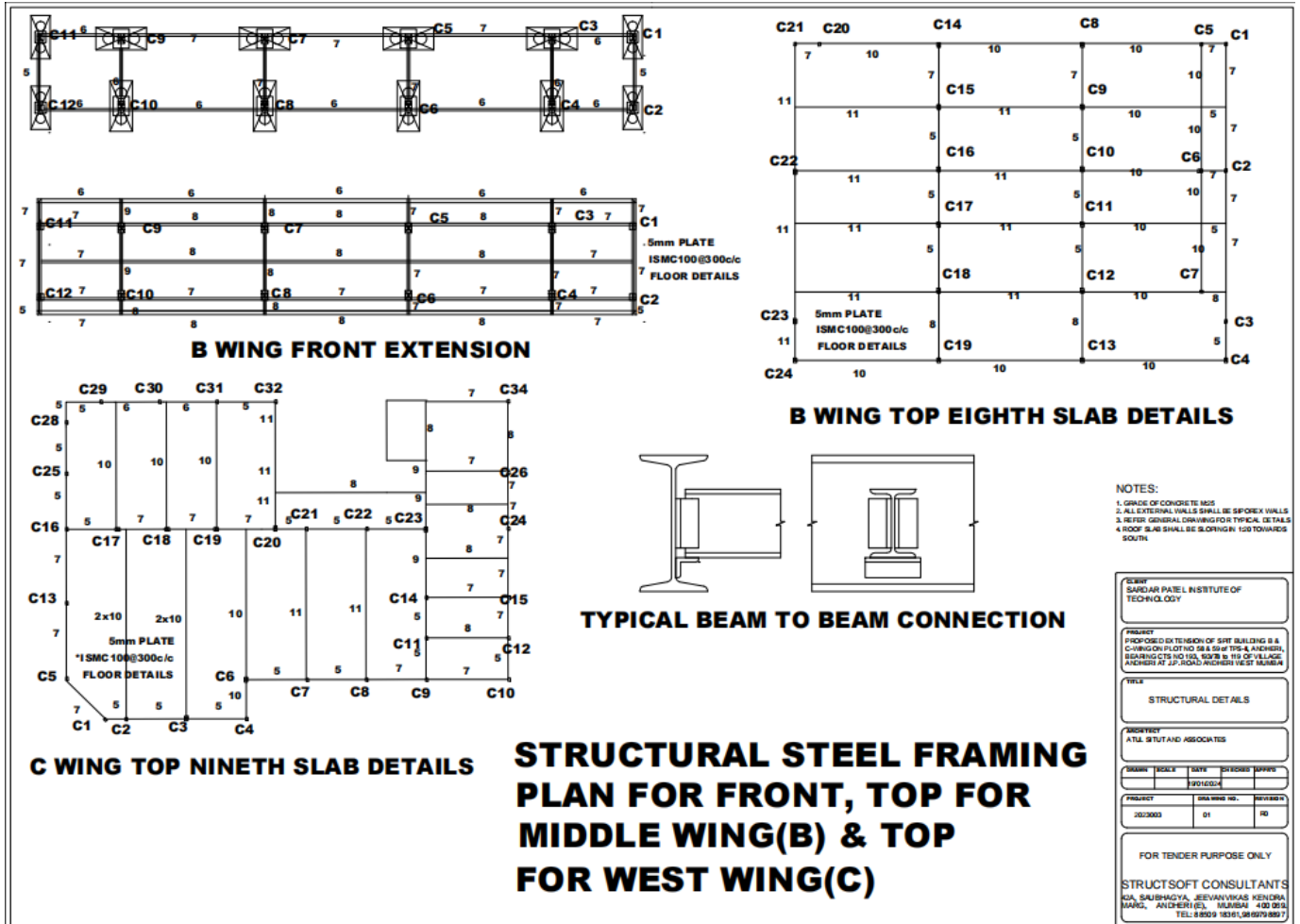

Photograph showing **EAST** wing where we have recently expanded existing G=4 to G+6 within 4 months including interiors



Photograph showing **MIDDLE** wing where we have planned a vertical expansion of existing G+6 to G+8; and front extension upto G+8. The pile work for the front extension is in progress and will be over by 15th April 25.



Photograph showing **WEST** wing where we have planned a vertical expansion of existing G+8 to G+10.

